

2-A, Fast-Transient, Low-Dropout Voltage Regulator

FEATURES

- **Low Dropout Voltage: 250 mV at 2 A**
- **V_{IN} Range: 1.5 V to 6.5 V**
- **Configurable Fixed V_{OUT} Range: 0.9 V to 3.5 V**
Adjustable V_{OUT} Range: 0.9 V to 5.0 V
- **Very Good Load and Line Transient Response**
- **Stable with Ceramic Output Capacitor**
- **2% Accuracy over Line, Load, and Temperature**
- **Programmable Softstart**
- **Power Good (PG) Output**
- **5-mm × 5-mm QFN-20 Package**

APPLICATIONS

- **Wireless Infrastructure: SerDes, FPGA, DSP™**
- **RF Components: VCO, ADC, DAC, LVDS**
- **Set-Top Boxes: Amplifier, ADC, DAC, FPGA, DSP**
- **Wireless LAN, Bluetooth®**
- **PCs and Printers**
- **Audio and Visual**

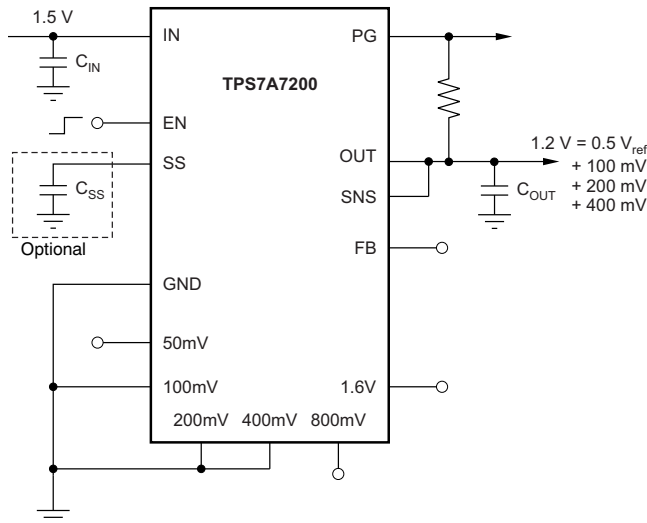

Typical Application

DESCRIPTION

The TPS7A7200 low-dropout (LDO) voltage regulator is designed for applications seeking very-low dropout capability (250 mV at 2 A) with an input voltage from 1.5 V to 6.5 V. The TPS7A7200 offers an innovative, user-configurable, output-voltage setting from 0.9 V to 3.5 V, eliminating external resistors and any associated error.

The TPS7A7200 has very fast load-transient response, is stable with ceramic output capacitors, and supports a better than 2% accuracy over line, load, and temperature. A soft-start pin allows for an application to reduce inrush into the load. Additionally, an open-drain, power-good signal allows for sequencing power rails.

The TPS7A7200 is available in a 5-mm × 5-mm, 20-pin QFN package.

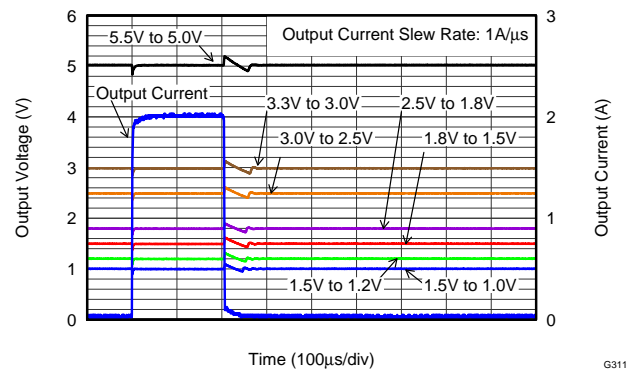

Load Transient Response with Seven Different Results:
1.5 V_{IN} to 1.0 V_{OUT}, 1.5 V_{IN} to 1.2 V_{OUT},
1.8 V_{IN} to 1.5 V_{OUT}, 2.5 V_{IN} to 1.8 V_{OUT},
3.0 V_{IN} to 2.5 V_{OUT}, 3.3 V_{IN} to 3.0 V_{OUT},
and 5.5 V_{IN} to 5.0 V_{OUT}

PRODUCT PREVIEW

G311



Please be aware that an important notice concerning availability, standard warranty, and use in critical applications of Texas Instruments semiconductor products and disclaimers thereto appears at the end of this data sheet.

DSP is a trademark of Texas Instruments.

Bluetooth is a registered trademark of Bluetooth SIG, Inc.

All other trademarks are the property of their respective owners.

PRODUCT PREVIEW information concerns products in the formative or design phase of development. Characteristic data and other specifications are design goals. Texas Instruments reserves the right to change or discontinue these products without notice.

Copyright © 2012, Texas Instruments Incorporated



This integrated circuit can be damaged by ESD. Texas Instruments recommends that all integrated circuits be handled with appropriate precautions. Failure to observe proper handling and installation procedures can cause damage.

ESD damage can range from subtle performance degradation to complete device failure. Precision integrated circuits may be more susceptible to damage because very small parametric changes could cause the device not to meet its published specifications.

ORDERING INFORMATION⁽¹⁾

PRODUCT	Description
TPS7A7200yyyz	YYY is package designator. Z is package quantity.

(1) For the most current package and ordering information see the Package Option Addendum at the end of this document, or see the device product folder at www.ti.com.

ABSOLUTE MAXIMUM RATINGS⁽¹⁾

Over operating free-air temperature range (unless otherwise noted).

		VALUE		UNIT
		MIN	MAX	
Voltage	IN, PG, EN	-0.3	+7.0	V
	SS, FB, SNS, OUT	-0.3	$V_{IN} + 0.3^{(2)}$	V
	50mV, 100mV, 200mV, 400mV, 800mV, 1.6V	-0.3	$V_{OUT} + 0.3$	V
Current	OUT	Internally limited		A
	PG (sink current into IC)	5		mA
Temperature	Operating virtual junction, T_J	-55	+150	°C
	Storage, T_{stg}	-55	+150	°C
Electrostatic Discharge Rating ⁽³⁾	Human body model (HBM, JESD22-A114A)	2		kV
	Charged device model (CDM, JESD22-C101B.01)	500		V

- (1) Stresses beyond those listed under *Absolute Maximum Ratings* may cause permanent damage to the device. These are stress ratings only, and functional operation of the device at these or any other conditions beyond those indicated is not implied. Exposure to absolute-maximum-rated conditions for extended periods may affect device reliability.
- (2) The absolute maximum rating is $V_{IN} + 0.3$ V or +7.0 V, whichever is smaller.
- (3) ESD testing is performed according to the respective JESD22 JEDEC standard.

THERMAL INFORMATION

THERMAL METRIC ⁽¹⁾⁽²⁾		TPS7A7200 ⁽³⁾		UNITS
		RGW		
		20 PINS		
θ_{JA}	Junction-to-ambient thermal resistance ⁽⁴⁾	30.5		°C/W
θ_{JCTop}	Junction-to-case (top) thermal resistance ⁽⁵⁾	27.6		
θ_{JB}	Junction-to-board thermal resistance ⁽⁶⁾	N/A		
ψ_{JT}	Junction-to-top characterization parameter ⁽⁷⁾	0.37		
ψ_{JB}	Junction-to-board characterization parameter ⁽⁸⁾	10.6		
θ_{JCbott}	Junction-to-case (bottom) thermal resistance ⁽⁹⁾	4.1		

- (1) For more information about traditional and new thermal metrics, see the [IC Package Thermal Metrics](#) application report, [SPRA953A](#).
- (2) For thermal estimates of this device based on PCB copper area, see the [TI PCB Thermal Calculator](#).
- (3) Thermal data for the RGW package is derived by thermal simulations based on JEDEC-standard methodology as specified in the JESD51 series. The following assumptions are used in the simulations:
 - (a) The exposed pad is connected to the PCB ground layer through a 4x4 thermal via array.
 - (b) Each of top and bottom copper layers has a dedicated pattern for 20% copper coverage.
 - (c) These data were generated with only a single device at the center of a JEDEC high-K (2s2p) board with 3in x 3in copper area. To understand the effects of the copper area on thermal performance, refer to the [Power Dissipation](#) and [Estimating Junction Temperature](#) sections.
- (4) The junction-to-ambient thermal resistance under natural convection is obtained in a simulation on a JEDEC-standard, high-K board, as specified in JESD51-7, in an environment described in JESD51-2a.
- (5) The junction-to-case (top) thermal resistance is obtained by simulating a cold plate test on the top of the package. No specific JEDEC-standard test exists, but a close description can be found in the ANSI SEMI standard G30-88.
- (6) The junction-to-board thermal resistance is obtained by simulating in an environment with a ring cold plate fixture to control the PCB temperature, as described in JESD51-8.
- (7) The junction-to-top characterization parameter, ψ_{JT} , estimates the junction temperature of a device in a real system and is extracted from the simulation data to obtain θ_{JA} using a procedure described in JESD51-2a (sections 6 and 7).
- (8) The junction-to-board characterization parameter, ψ_{JB} , estimates the junction temperature of a device in a real system and is extracted from the simulation data to obtain θ_{JA} using a procedure described in JESD51-2a (sections 6 and 7).
- (9) The junction-to-case (bottom) thermal resistance is obtained by simulating a cold plate test on the exposed (power) pad. No specific JEDEC standard test exists, but a close description can be found in the ANSI SEMI standard G30-88.

ELECTRICAL CHARACTERISTICS

Over operating temperature range ($T_J = -40^\circ\text{C}$ to $+125^\circ\text{C}$), $1.425\text{ V} \leq V_{IN} \leq 6.5\text{ V}$, $V_{IN} \geq V_{OUT(\text{TARGET})} + 0.3\text{ V}$ or $V_{IN} \geq V_{OUT(\text{TARGET})} + 0.5\text{ V}^{(1)(2)}$, OUT connected to $50\ \Omega$ to GND⁽³⁾, $V_{EN} = 1.1\text{ V}$, $C_{OUT} = 10\ \mu\text{F}$, $C_{SS} = 10\text{ nF}$, and PG pin pulled up to V_{IN} with $100\text{ k}\Omega$, $27\text{ k}\Omega \leq R2 \leq 33\text{ k}\Omega$ for adjustable configuration⁽⁴⁾, unless otherwise noted.

Typical values are at $T_J = +25^\circ\text{C}$.

PARAMETER		TEST CONDITIONS	MIN	TYP	MAX	UNIT
V_{IN}	Input voltage range		1.425		6.5	V
$V_{(SS)}$	SS pin voltage			0.5		V
V_{OUT}	Output voltage range	Adjustable with external feedback resistors	0.9		5.0	V
		Fixed with voltage setting pins	0.9		3.5	
	Output voltage accuracy ⁽⁵⁾⁽⁶⁾	Adjustable, $25\text{ mA} \leq I_{OUT} \leq 2\text{ A}$	-2.0		+2.0	%
		Fixed, $25\text{ mA} \leq I_{OUT} \leq 2\text{ A}$	-3.0		+3.0	
$\Delta V_{O(\Delta VI)}$	Line regulation	$I_{OUT} = 25\text{ mA}$		0.01		%/V
$\Delta V_{O(\Delta IO)}$	Load regulation	$25\text{ mA} \leq I_{OUT} \leq 2\text{ A}$		0.1		%/A
$V_{(DO)}$	Dropout voltage ⁽⁷⁾	$V_{OUT} \leq 3.3\text{ V}$, $I_{OUT} = 2\text{ A}$, $V_{(FB)} = \text{GND}$			250	mV
		$3.3\text{ V} < V_{OUT}$, $I_{OUT} = 2\text{ A}$, $V_{(FB)} = \text{GND}$			450	mV
$I_{(LIM)}$	Output current limit	V_{OUT} forced at $0.9 \times V_{OUT(\text{TARGET})}$, $V_{IN} = 3.3\text{ V}$, $V_{OUT(\text{TARGET})} = 0.9\text{ V}$	2.1	3.1	3.7	A
$I_{(GND)}$	GND pin current	Full load, $I_{OUT} = 2\text{ A}$		2.6		mA
		Minimum load, $V_{IN} = 6.5\text{ V}$, $V_{OUT(\text{TARGET})} = 0.9\text{ V}$, $I_{OUT} = 25\text{ mA}$			5	mA
		Shutdown, PG = (open), $V_{IN} = 6.5\text{ V}$, $V_{OUT(\text{TARGET})} = 0.9\text{ V}$, $V_{(EN)} < 0.5\text{ V}$			5	μA
$I_{(EN)}$	EN pin current	$V_{IN} = 6.5\text{ V}$, $V_{(EN)} = 0\text{ V}$ and 6.5 V			± 0.1	μA
$V_{IL(\text{EN})}$	EN pin low-level input voltage (disable device)		0		0.5	V
$V_{IH(\text{EN})}$	EN pin high-level input voltage (enable device)		1.1		6.5	V
$V_{IT(\text{PG})}$	PG pin threshold	For the direction PG \downarrow with decreasing V_{OUT}	$0.86V_{OUT}$	$0.9V_{OUT}$	$0.96V_{OUT}$	V
$V_{hys(\text{PG})}$	PG pin hysteresis	For PG \uparrow		$0.02V_{OUT}$		V
$V_{OL(\text{PG})}$	PG pin low-level output voltage	$V_{OUT} < V_{IT(\text{PG})}$, $I_{PG} = -1\text{ mA}$ (current into device)			0.4	V
$I_{lk(\text{PG})}$	PG pin leakage current	$V_{OUT} > V_{IT(\text{PG})}$, $V_{(PG)} = 6.5\text{ V}$			1	μA
$I_{(SS)}$	SS pin charging current	$V_{(SS)} = \text{GND}$, $V_{IN} = 3.3\text{ V}$	3.5	6.0	7.2	μA
V_n	Output noise voltage	BW = 100 Hz to 100 kHz, $V_{IN} = 1.5\text{ V}$, $V_{OUT} = 1.2\text{ V}$, $I_{OUT} = 2\text{ A}$		40.65		μV_{RMS}
T_{sd}	Thermal shutdown temperature	Shutdown, temperature increasing		+160		$^\circ\text{C}$
		Reset, temperature decreasing		+140		$^\circ\text{C}$
T_J	Operating junction temperature		-40		+125	$^\circ\text{C}$

- (1) When $V_{OUT} \leq 3.5\text{ V}$, $V_{IN} \geq (V_{OUT} + 0.3\text{ V})$ or 1.425 V , whichever is greater; when $V_{OUT} > 3.5\text{ V}$, $V_{IN} \geq (V_{OUT} + 0.5\text{ V})$.
- (2) $V_{OUT(\text{TARGET})}$ is the calculated target V_{OUT} value from the output voltage setting pins: 50mV, 100mV, 200mV, 400mV, 800mV, and 1.6V in fixed configuration, or the expected V_{OUT} value set by external feedback resistors in adjustable configuration.
- (3) This 50- Ω load is disconnected when the test conditions specify an I_{OUT} value.
- (4) R2 is the bottom-side of the feedback resistor between the FB pin and GND. See [Figure 40](#) for details.
- (5) When the TPS7A7200 is connected to external feedback resistors at the FB pin, external resistor tolerances are not included.
- (6) The TPS7A7200 is not tested at $V_{OUT} = 0.9\text{ V}$, $2.7\text{ V} \leq V_{IN} \leq 6.5\text{ V}$, and $500\text{ mA} \leq I_{OUT} \leq 2\text{ A}$ because the power dissipation is higher than the maximum rating of the package. Also, this accuracy specification does not apply on any application condition that exceeds the power dissipation limit of the package.
- (7) $V_{(DO)}$ is not defined for output voltage settings below 1.2 V.

FUNCTIONAL BLOCK DIAGRAM

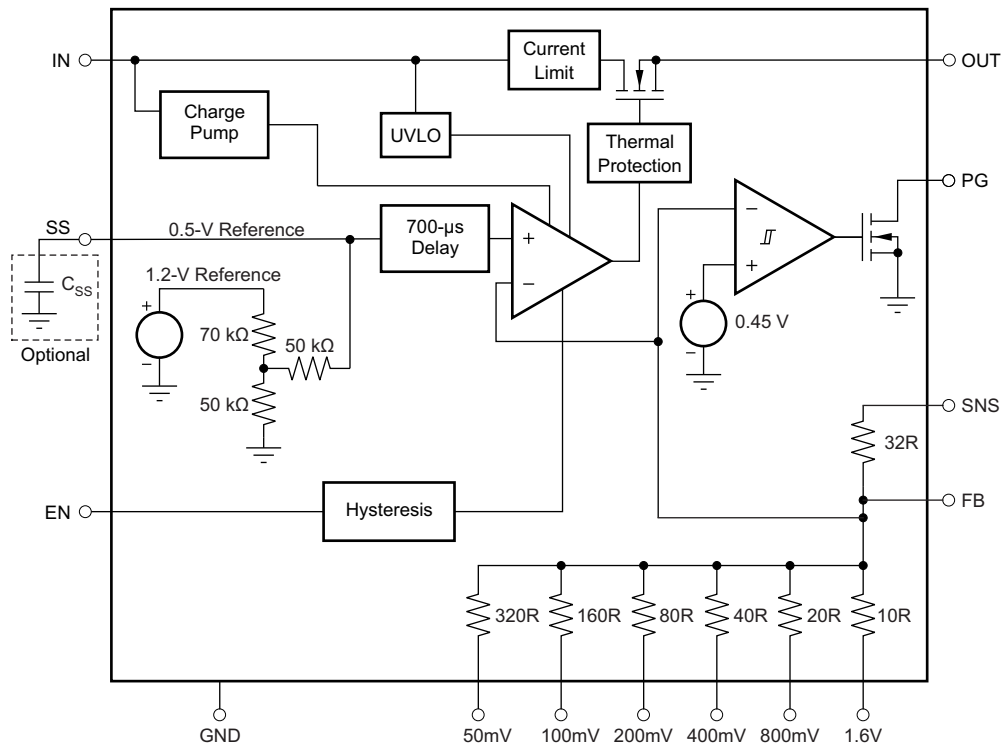

NOTE: 320R = 1.024 MΩ (that is, 1R = 3.2 kΩ).

Figure 1. Functional Block Diagram

PRODUCT PREVIEW

PIN CONFIGURATIONS

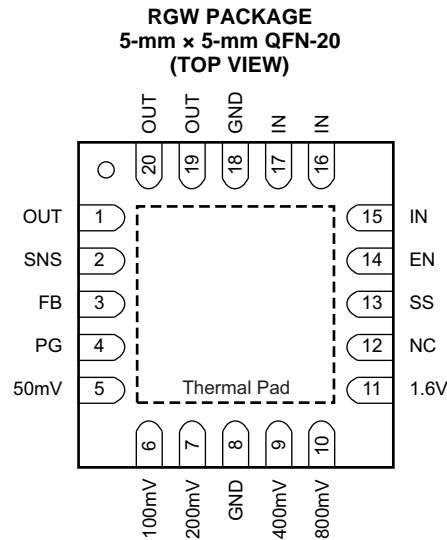

PIN DESCRIPTIONS

NAME	PIN #	DESCRIPTION
50mV, 100mV, 200mV, 400mV, 800mV, 1.6V	5, 6, 7, 9, 10, 11	Output voltage setting pins. These pins should be connected to ground or left floating. Connecting these pins to ground increases the output voltage by the value of the pin name; multiple pins can be simultaneously connected to GND to select the desired output voltage. Leave these pins floating (open) when not in use. See the USER-CONFIGURABLE OUTPUT VOLTAGE section for more details.
EN	14	Enable pin. Driving this pin to logic high enables the device; driving the pin to logic low disables the device. See the ENABLE AND SHUTDOWN THE DEVICE section for more details.
FB	3	Output voltage feedback pin. Connected to the error amplifier. See the USER-CONFIGURABLE OUTPUT VOLTAGE and TRADITIONAL ADJUSTABLE CONFIGURATION sections for more details.
GND	8, 18	Ground pin.
IN	15, 16, 17	Unregulated supply voltage pin. It is recommended to connect an input capacitor to this pin. See INPUT CAPACITOR REQUIREMENTS for more details.
NC	12	Not internally connected. The NC pin is not connected to any electrical node. It is strongly recommended to connect this pin and the thermal pad to a large-area ground plane. See the Power Dissipation section for more details.
OUT	1, 19, 20	Regulated output pin. A 4.7- μ F or larger capacitance is required for stability. See OUTPUT CAPACITOR REQUIREMENTS for more details.
PG	4	Active-high power good pin. An open-drain output that indicates when the output voltage reaches 90% of the target. See POWER GOOD for more details.
SNS	2	Output voltage sense input pin. See the USER-CONFIGURABLE OUTPUT VOLTAGE and TRADITIONAL ADJUSTABLE CONFIGURATION sections for more details.
SS	13	Soft-start pin. Leaving this pin open provides soft-start of the default setting. Connecting an external capacitor between this pin and the ground enables the soft-start function by forming an RC-delay circuit in combination with the integrated resistance on the silicon. See the SOFT-START section for more details.
Thermal Pad	Pad	It is strongly recommended to connect the thermal pad to a large-area ground plane. If available, connect an electrically-floating, dedicated thermal plane to the thermal pad as well.

TYPICAL CHARACTERISTICS

At $T_J = +25^\circ\text{C}$, $V_{IN} = V_{OUT(TARGET)} + 0.3\text{ V}$, $I_{OUT} = 25\text{ mA}$, $V_{(EN)} = V_{IN}$, $C_{IN} = 10\ \mu\text{F}$, $C_{OUT} = 10\ \mu\text{F}$, $C_{(SS)} = 10\ \text{nF}$, and the PG pin pulled up to V_{IN} with 100-k Ω pull-up resistor, unless otherwise noted.

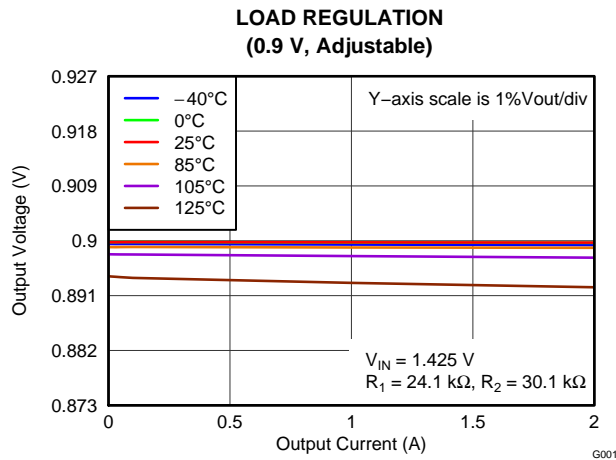

Figure 2.

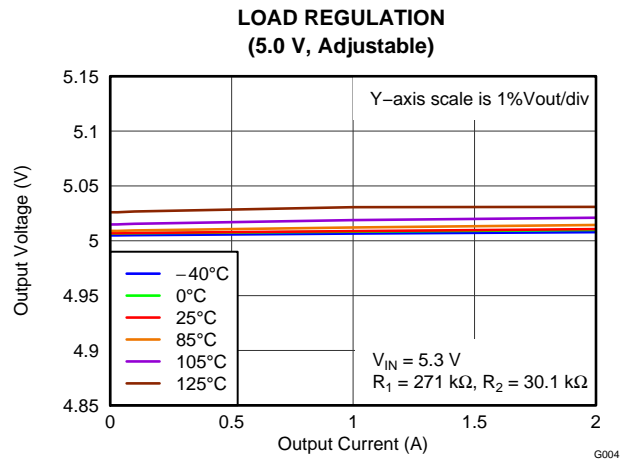

Figure 3.

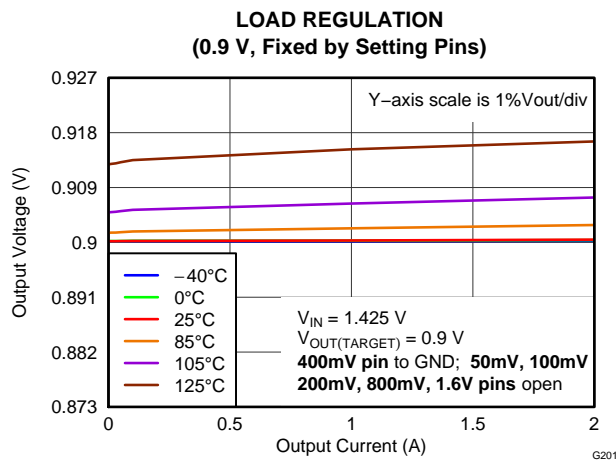

Figure 4.

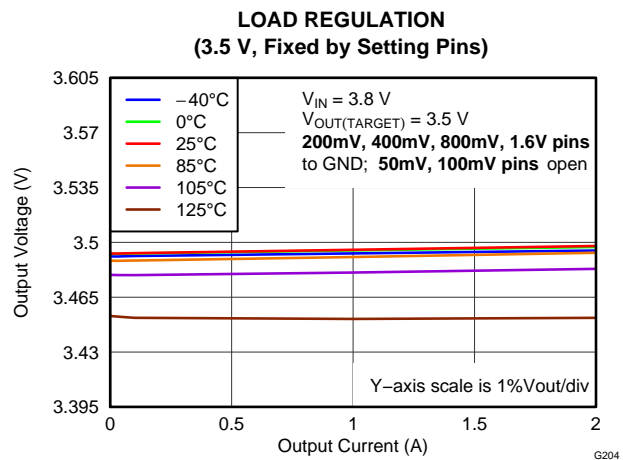

Figure 5.

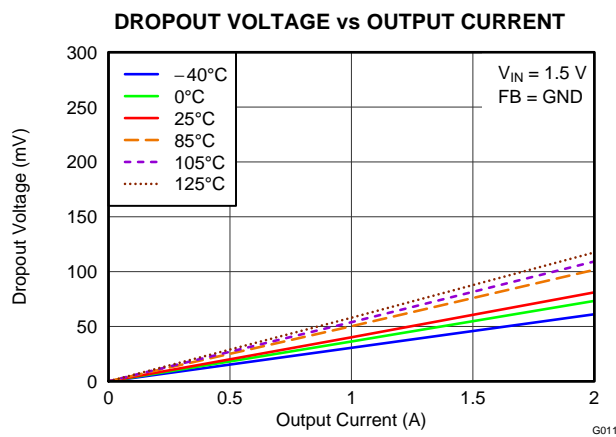

Figure 6.

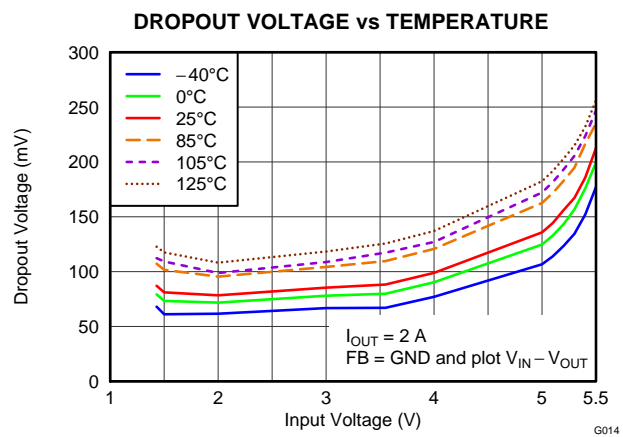

Figure 7.

PRODUCT PREVIEW

TYPICAL CHARACTERISTICS (continued)

At $T_J = +25^\circ\text{C}$, $V_{IN} = V_{OUT(TARGET)} + 0.3\text{ V}$, $I_{OUT} = 25\text{ mA}$, $V_{(EN)} = V_{IN}$, $C_{IN} = 10\text{ }\mu\text{F}$, $C_{OUT} = 10\text{ }\mu\text{F}$, $C_{(SS)} = 10\text{ nF}$, and the PG pin pulled up to V_{IN} with 100-k Ω pull-up resistor, unless otherwise noted.

**LINE REGULATION
(0.9 V, Adjustable)**

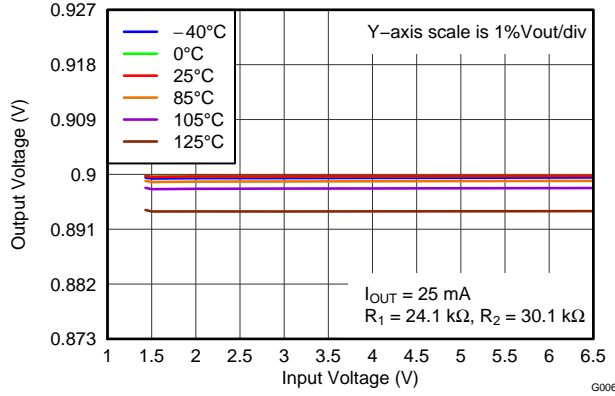

Figure 8.

**LINE REGULATION
(5.0 V, Adjustable)**

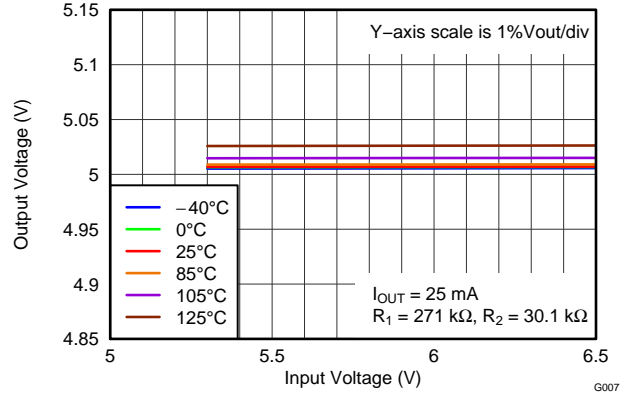

Figure 9.

**LINE REGULATION
(0.9 V, Fixed by Setting Pins)**

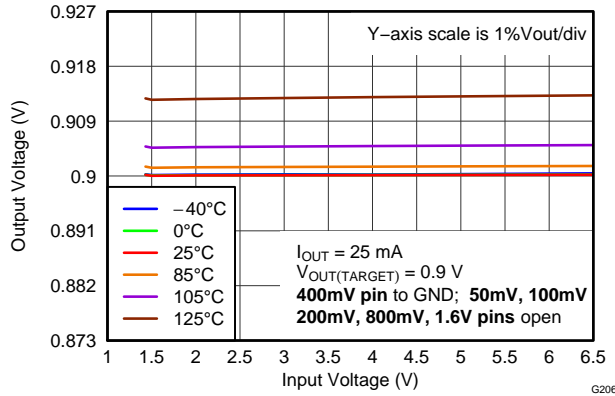

Figure 10.

**LINE REGULATION
(3.5 V, Fixed by Setting Pins)**

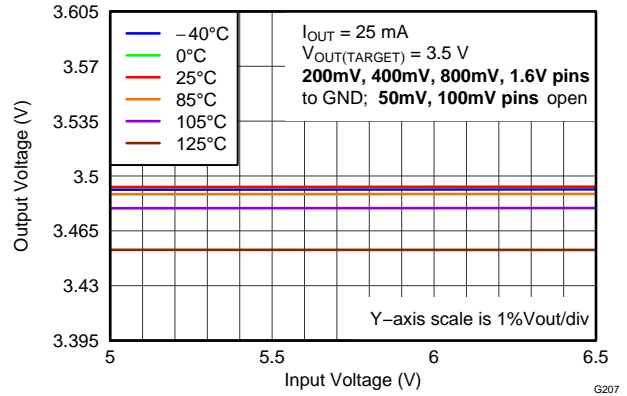

Figure 11.

**OUTPUT VOLTAGE:
ACTUAL vs PIN-SETTING**

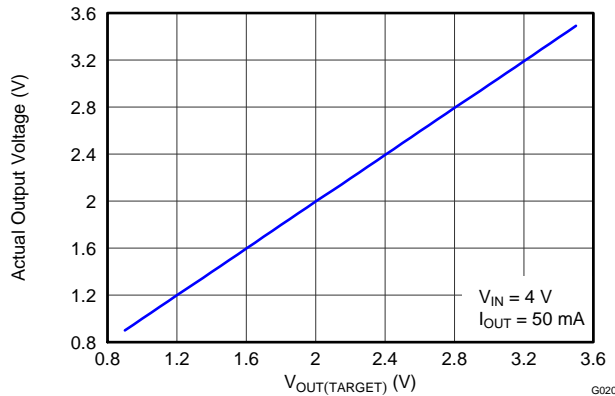

Figure 12.

**OUTPUT VOLTAGE:
ACTUAL (Normalized) vs PIN-SETTING**

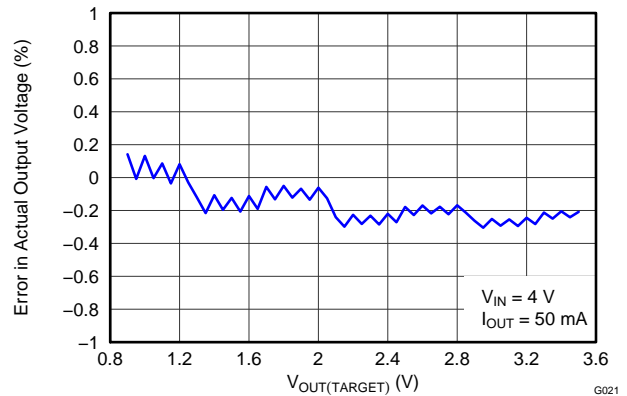

Figure 13.

PRODUCT PREVIEW

TYPICAL CHARACTERISTICS (continued)

At $T_J = +25^\circ\text{C}$, $V_{IN} = V_{OUT(TARGET)} + 0.3\text{ V}$, $I_{OUT} = 25\text{ mA}$, $V_{(EN)} = V_{IN}$, $C_{IN} = 10\ \mu\text{F}$, $C_{OUT} = 10\ \mu\text{F}$, $C_{(SS)} = 10\ \text{nF}$, and the PG pin pulled up to V_{IN} with 100-k Ω pull-up resistor, unless otherwise noted.

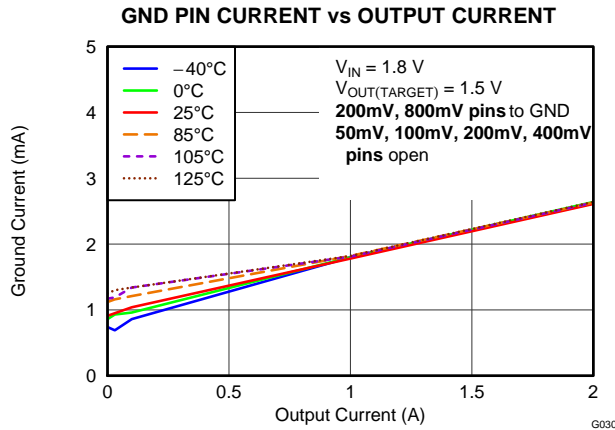

Figure 14.

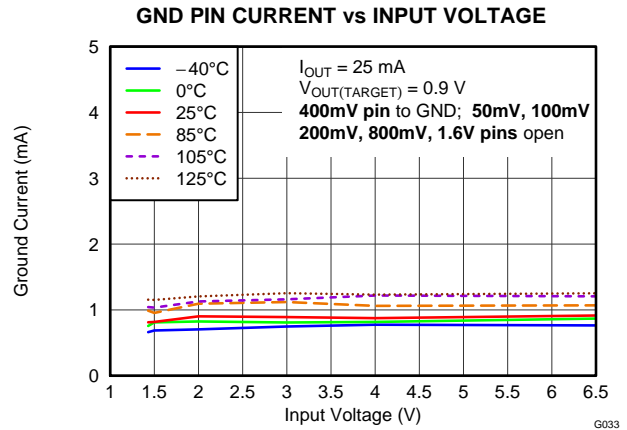

Figure 15.

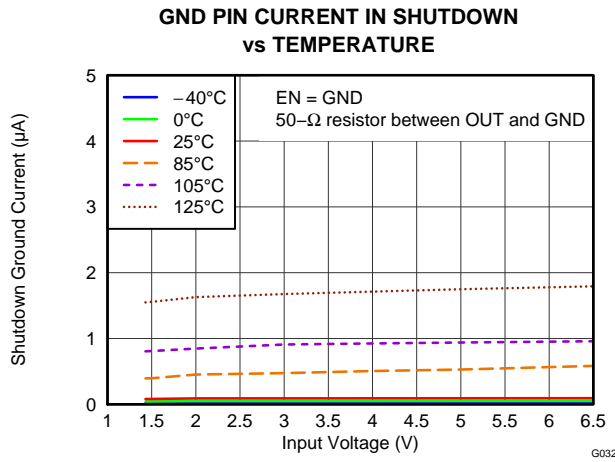

Figure 16.

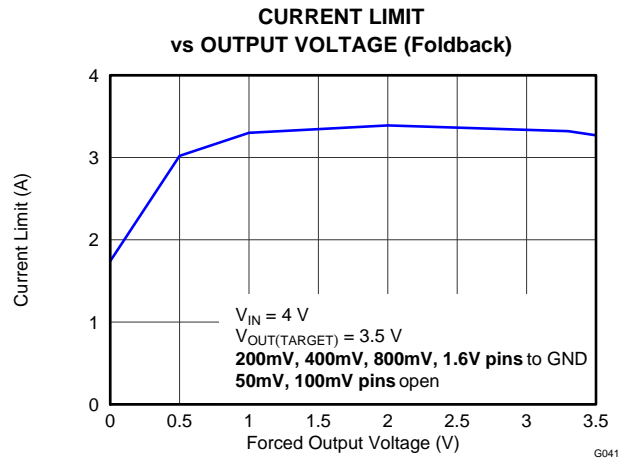

Figure 17.

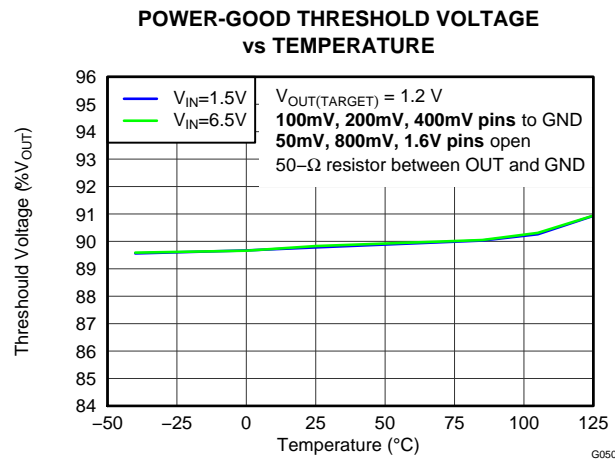

Figure 18.

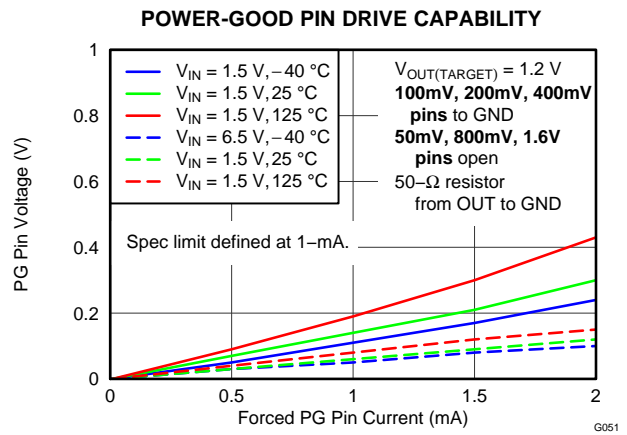

Figure 19.

PRODUCT PREVIEW

TYPICAL CHARACTERISTICS (continued)

At $T_J = +25^\circ\text{C}$, $V_{IN} = V_{OUT(TARGET)} + 0.3\text{ V}$, $I_{OUT} = 25\text{ mA}$, $V_{(EN)} = V_{IN}$, $C_{IN} = 10\text{ }\mu\text{F}$, $C_{OUT} = 10\text{ }\mu\text{F}$, $C_{(SS)} = 10\text{ nF}$, and the PG pin pulled up to V_{IN} with 100-k Ω pull-up resistor, unless otherwise noted.

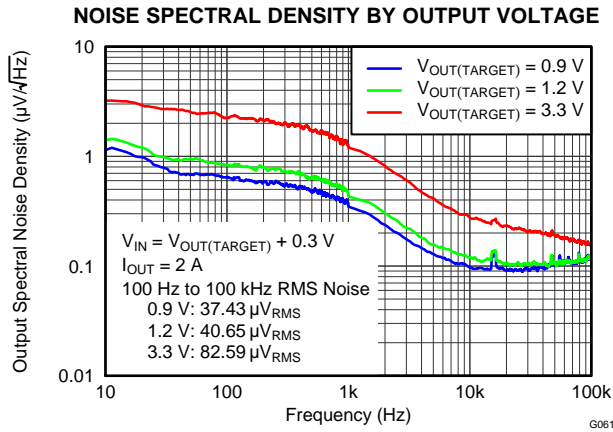

Figure 20.

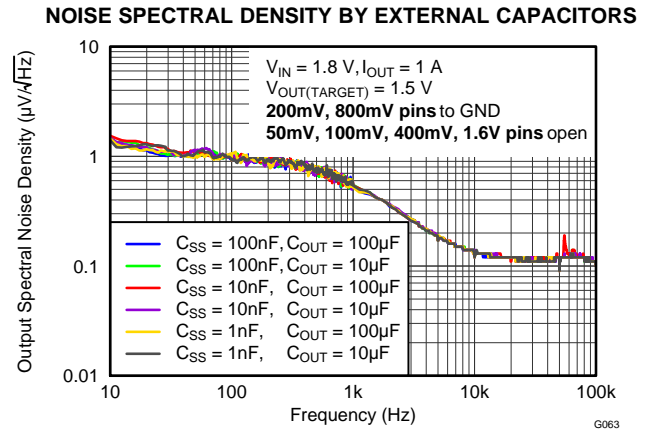

Figure 21.

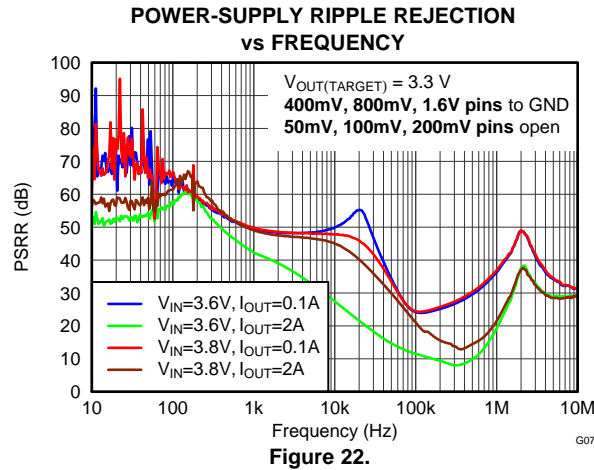

Figure 22.

PRODUCT PREVIEW

TYPICAL CHARACTERISTICS (continued)

At $T_J = +25^\circ\text{C}$, $V_{IN} = V_{OUT(TARGET)} + 0.3\text{ V}$, $I_{OUT} = 25\text{ mA}$, $V_{(EN)} = V_{IN}$, $C_{IN} = 10\text{ }\mu\text{F}$, $C_{OUT} = 10\text{ }\mu\text{F}$, $C_{(SS)} = 10\text{ nF}$, and the PG pin pulled up to V_{IN} with 100-k Ω pull-up resistor, unless otherwise noted.

LOAD TRANSIENT RESPONSE
($V_{OUT} = 1.2\text{ V}$)

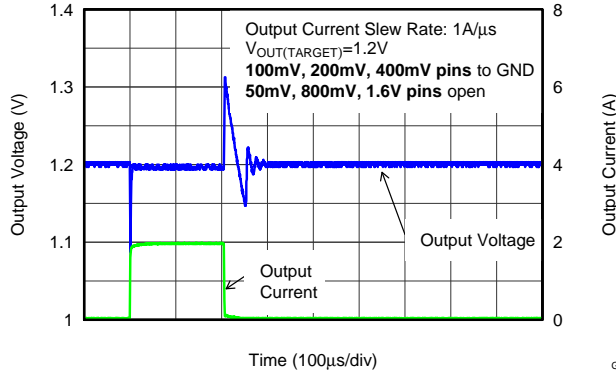

Figure 23.

G314

LOAD TRANSIENT RESPONSE
($V_{OUT} = 3.3\text{ V}$)

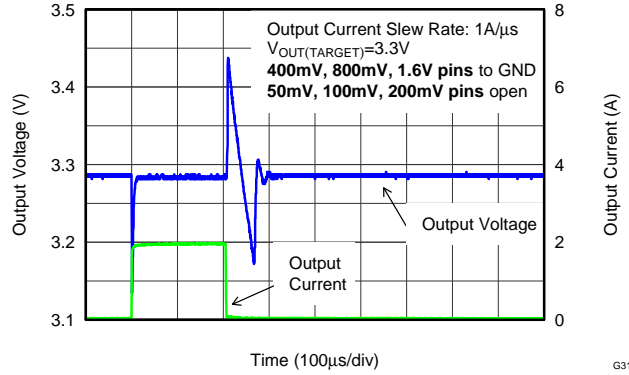

Figure 24.

G317

LINE TRANSIENT RESPONSE

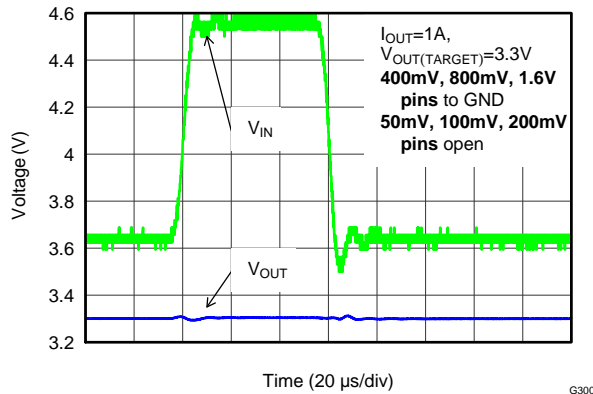

Figure 25.

G300

POWER-UP/POWER-DOWN (IN = EN)

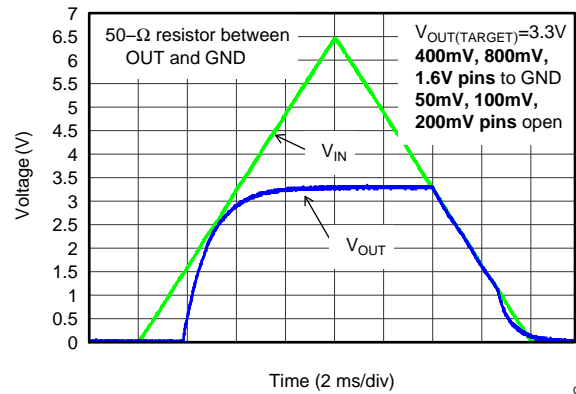

Figure 26.

G301

TURN-ON RESPONSE (IN = EN)

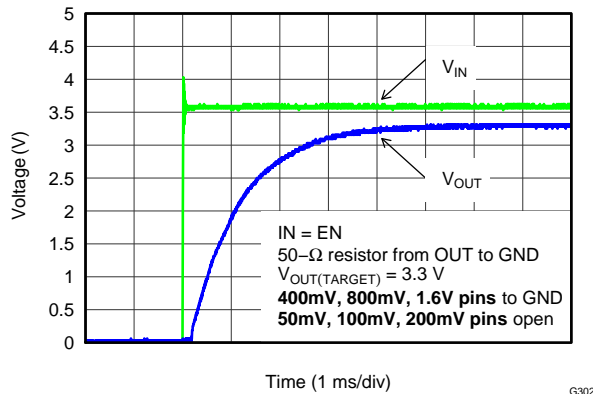

Figure 27.

G302

TURN-OFF RESPONSE (IN = EN)

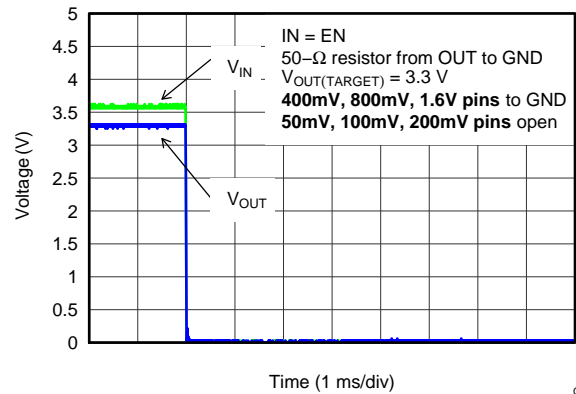

Figure 28.

G303

PRODUCT PREVIEW

TYPICAL CHARACTERISTICS (continued)

At $T_J = +25^\circ\text{C}$, $V_{IN} = V_{OUT(TARGET)} + 0.3\text{ V}$, $I_{OUT} = 25\text{ mA}$, $V_{(EN)} = V_{IN}$, $C_{IN} = 10\ \mu\text{F}$, $C_{OUT} = 10\ \mu\text{F}$, $C_{SS} = 10\ \text{nF}$, and the PG pin pulled up to V_{IN} with 100-k Ω pull-up resistor, unless otherwise noted.

**EN PULSE ON RESPONSE
(Over Stable V_{IN})**

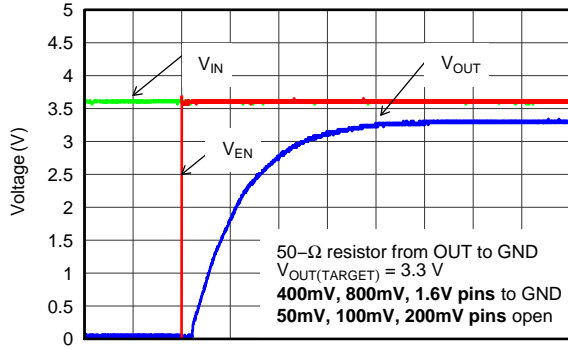

Time (1 ms/div)

G304

Figure 29.

**EN PULSE OFF RESPONSE
(Over Stable V_{IN})**

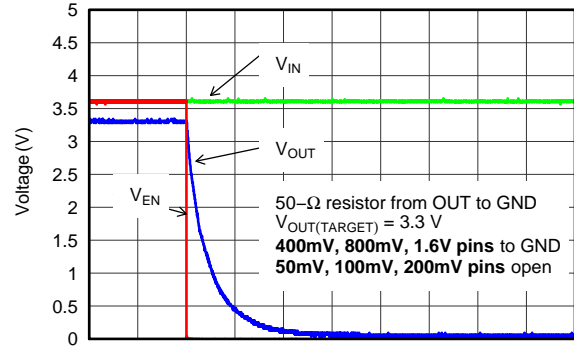

Time (1 ms/div)

G305

Figure 30.

SOFT-START DELAY vs C_{SS} (Enlarged View)

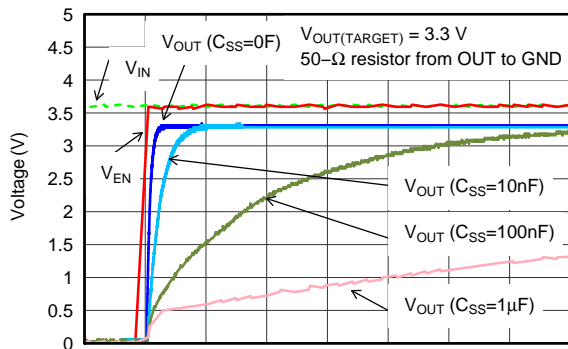

Time (5 ms/div)

G306

Figure 31.

SOFT-START DELAY vs C_{SS} (Reduced View)

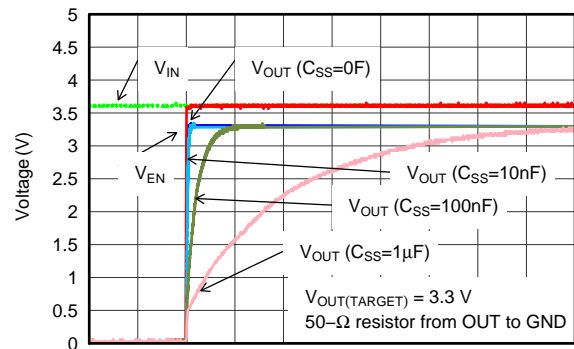

Time (50 ms/div)

G307

Figure 32.

SOFT-START DELAY vs C_{SS}

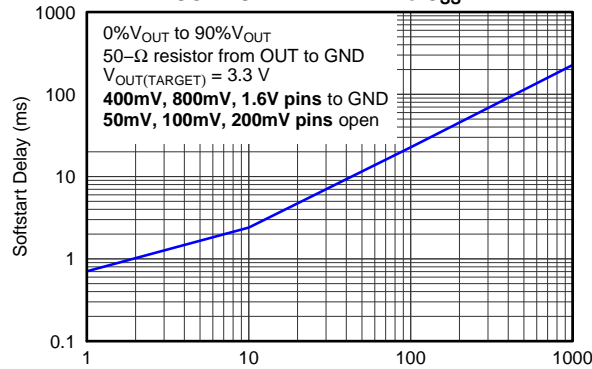

Figure 33.

G308

APPLICATION INFORMATION

OVERVIEW

The TPS7A7200 belongs to a family of new-generation LDO regulators that uses innovative circuitry to offer very-low dropout voltage along with the flexibility of a programmable output voltage.

The dropout voltage for this LDO regulator family is 0.25 V at 2 A. This voltage is ideal for making the TPS7A7200 into a point-of-load (POL) regulator because 0.25 V at 2 A is lower than any voltage gap among the most common voltage rails: 1.2 V, 1.5 V, 1.8 V, 2.5 V, 3.0 V, and 3.3 V. This device offers a fully user-configurable output voltage setting method. The TPS7A7200 output voltage can be programmed to any target value from 0.9 V to 3.5 V in 50-mV steps.

Another big advantage of using the TPS7A7200 is the wide range of available operating input voltages: from 1.5 V to 6.5 V. The TPS7A7200 also has very good line and load transient response. All these features allow the TPS7A7200 to meet most voltage-regulator needs for under-6-V applications, using only one device so that less time is spent on inventory control.

Texas Instruments also offers different output current ratings with other family devices: the TPS7A7100 (1 A) and TPS7A7300 (3 A).

USER-CONFIGURABLE OUTPUT VOLTAGE

Unlike traditional LDO devices, the TPS7A7200 comes with only one orderable part number; there is no adjustable or fixed output voltage option. The output voltage of the TPS7A7200 is selectable in accordance with the names given to the output voltage setting pins: 50mV, 100mV, 200mV, 400mV, 800mV, and 1.6V. For each pin connected to the ground, the output voltage setting increases by the value associated with that pin name, starting from the value of the reference voltage of 0.5 V; floating the pin(s) has no effect on the output voltage. Figure 34 through Figure 39 show examples how to program the output voltages.

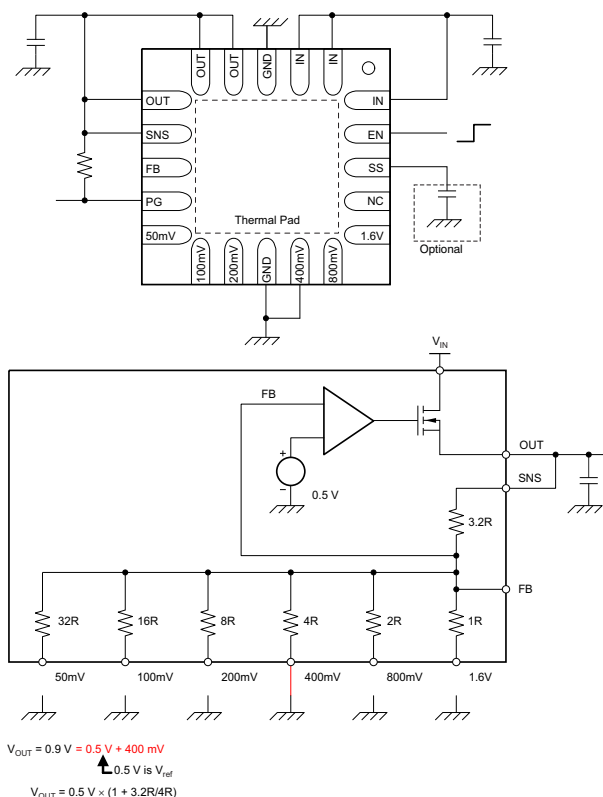

Figure 34. 0.9-V Configuration

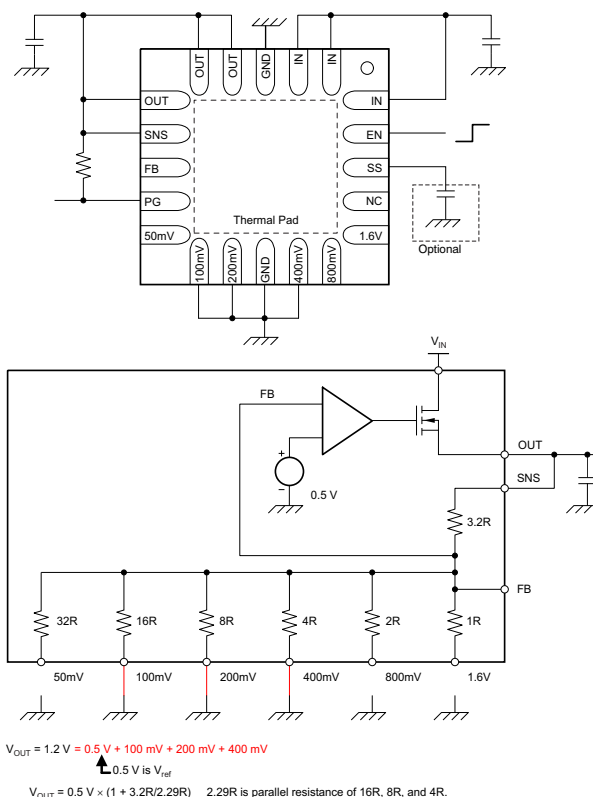
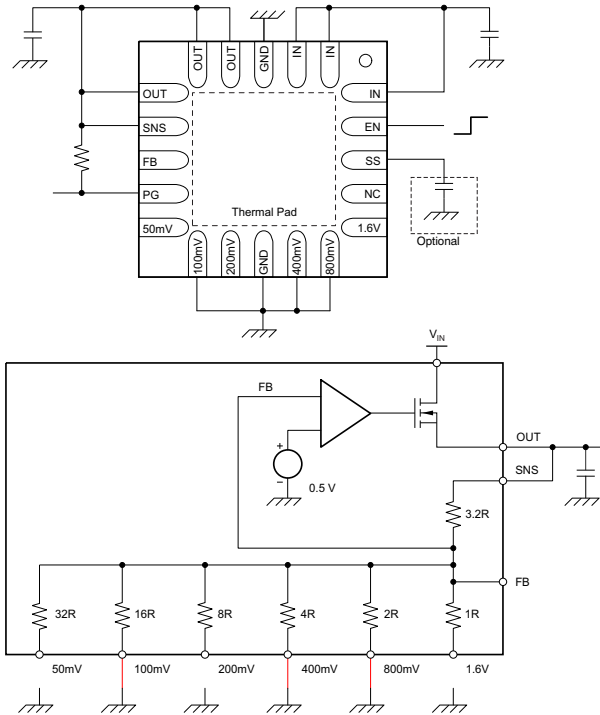
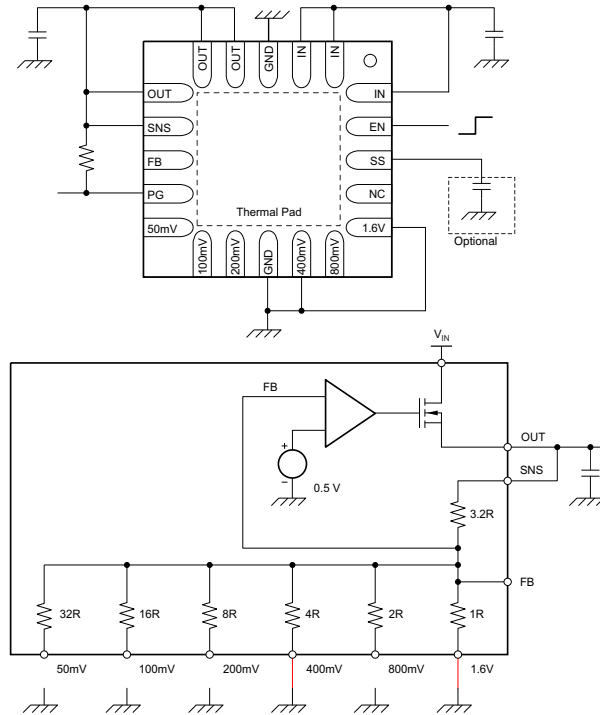

Figure 35. 1.2-V Configuration



$V_{OUT} = 1.8\text{ V} = 0.5\text{ V} + 100\text{ mV} + 400\text{ mV} + 800\text{ mV}$
 $V_{OUT} = 0.5\text{ V} \times (1 + 3.2R/1.23R)$ 1.23R is parallel resistance of 16R, 4R, and 2R.

Figure 36. 1.8-V Configuration



$V_{OUT} = 2.5\text{ V} = 0.5\text{ V} + 400\text{ mV} + 1.6\text{ V}$
 $V_{OUT} = 0.5\text{ V} \times (1 + 3.2R/0.8R)$ 0.8R is parallel resistance of 4R and 1R.

Figure 37. 2.5-V Configuration

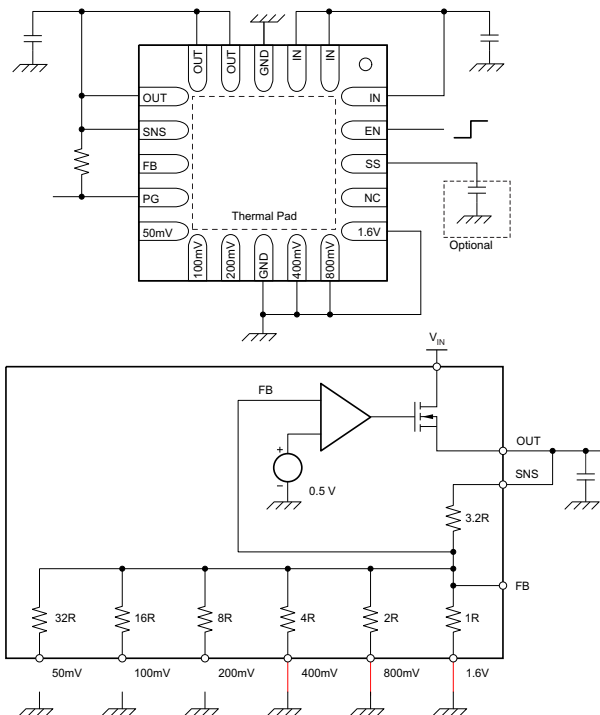

$V_{OUT} = 3.3\text{ V} = 0.5\text{ V} + 400\text{ mV} + 800\text{ mV} + 1.6\text{ V}$
 $V_{OUT} = 0.5\text{ V} \times (1 + 3.2R/0.571R)$ 0.571R is parallel resistance of 4R, 2R, and 1R.

Figure 38. 3.3-V Configuration

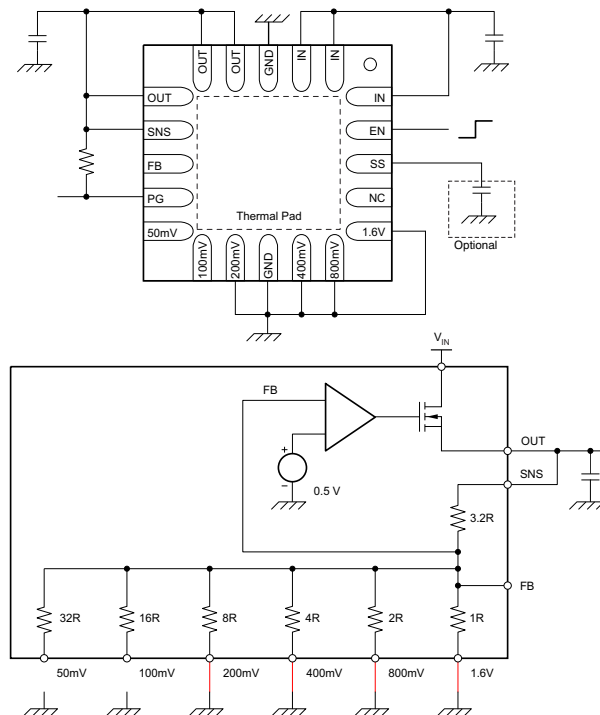

$V_{OUT} = 3.5\text{ V} = 0.5\text{ V} + 200\text{ mV} + 400\text{ mV} + 800\text{ mV} + 1.6\text{ V}$
 $V_{OUT} = 0.5\text{ V} \times (1 + 3.2R/0.533R)$ 0.533R is parallel resistance of 8R, 4R, 2R, and 1R.

Figure 39. 3.5-V Configuration

PRODUCT PREVIEW

See [Table 1](#) for a full list of target output voltages and corresponding pin settings. The voltage setting pins have a binary weight; therefore, the output voltage can be programmed to any value from 0.9 V to 3.5 V in 50-mV steps.

[Figure 12](#) and [Figure 13](#) shows this output voltage programming performance.

NOTE

Any output voltage setting that is not listed in [Table 1](#) is not covered in the Electrical Characteristics. For output voltages greater than 3.5 V, use a traditional adjustable configuration (see the [TRADITIONAL ADJUSTABLE CONFIGURATION](#) section).

Table 1. User Configurable Output Voltage Setting

V _{OUT(TARGET)} (V)	50mV	100mV	200mV	400mV	800mV	1.6V	V _{OUT(TARGET)} (V)	50mV	100mV	200mV	400mV	800mV	1.6V
0.90	open	open	open	GND	open	open	2.25	GND	GND	open	open	open	GND
0.95	GND	open	open	GND	open	open	2.30	open	open	GND	open	open	GND
1.00	open	GND	open	GND	open	open	2.35	GND	open	GND	open	open	GND
1.05	GND	GND	open	GND	open	open	2.40	open	GND	GND	open	open	GND
1.10	open	open	GND	GND	open	open	2.45	GND	GND	GND	open	open	GND
1.15	GND	open	GND	GND	open	open	2.50	open	open	open	GND	open	GND
1.20	open	GND	GND	GND	open	open	2.55	GND	open	open	GND	open	GND
1.25	GND	GND	GND	GND	open	open	2.60	open	GND	open	GND	open	GND
1.30	open	open	open	open	GND	open	2.65	GND	GND	open	GND	open	GND
1.35	GND	open	open	open	GND	open	2.70	open	open	GND	GND	open	GND
1.40	open	GND	open	open	GND	open	2.75	GND	open	GND	GND	open	GND
1.45	GND	GND	open	open	GND	open	2.80	open	GND	GND	GND	open	GND
1.50	open	open	GND	open	GND	open	2.85	GND	GND	GND	GND	open	GND
1.55	GND	open	GND	open	GND	open	2.90	open	open	open	open	GND	GND
1.60	open	GND	GND	open	GND	open	2.95	GND	open	open	open	GND	GND
1.65	GND	GND	GND	open	GND	open	3.00	open	GND	open	open	GND	GND
1.70	open	open	open	GND	GND	open	3.05	GND	GND	open	open	GND	GND
1.75	GND	open	open	GND	GND	open	3.10	open	open	GND	open	GND	GND
1.80	open	GND	open	GND	GND	open	3.15	GND	open	GND	open	GND	GND
1.85	GND	GND	open	GND	GND	open	3.20	open	GND	GND	open	GND	GND
1.90	open	open	GND	GND	GND	open	3.25	GND	GND	GND	open	GND	GND
1.95	GND	open	GND	GND	GND	open	3.30	open	open	open	GND	GND	GND
2.00	open	GND	GND	GND	GND	open	3.35	GND	open	open	GND	GND	GND
2.05	GND	GND	GND	GND	GND	open	3.40	open	GND	open	GND	GND	GND
2.10	open	open	open	open	open	GND	3.45	GND	GND	open	GND	GND	GND
2.15	GND	open	open	open	open	GND	3.50	open	open	GND	GND	GND	GND
2.20	open	GND	open	open	open	GND							

TRADITIONAL ADJUSTABLE CONFIGURATION

For any output voltage target that is not supported in the [USER-CONFIGURABLE OUTPUT VOLTAGE](#) section, a traditional adjustable configuration with external-feedback resistors can be used with the TPS7A7200. [Figure 40](#) shows how to configure the TPS7A7200 as an adjustable regulator with an equation and [Table 2](#) lists recommended pairs of feedback resistor values.

NOTE

The bottom side of feedback resistor R2 in [Figure 40](#) should be in the range of 27 kΩ to 33 kΩ in order to maintain the specified regulation accuracy.

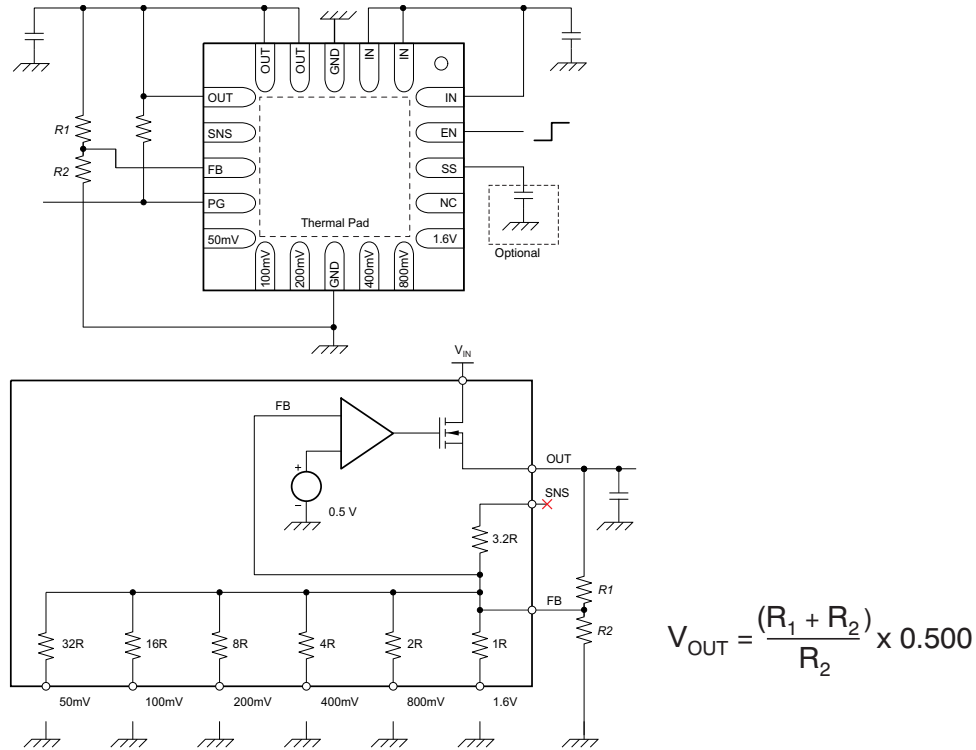

Figure 40. Traditional Adjustable Configuration with External Resistors

Table 2. Recommended Feedback-Resistor Values

V _{OUT(TARGET)} (V)	E96 SERIES		R40 SERIES	
	R1 (kΩ)	R2 (kΩ)	R1 (kΩ)	R2 (kΩ)
1.00	30.1	30.1	30.0	30.0
1.20	39.2	28.0	43.7	31.5
1.50	61.9	30.9	60.0	30.0
1.80	80.6	30.9	80.0	30.7
1.90	86.6	30.9	87.5	31.5
2.50	115	28.7	112	28.0
3.00	147	29.4	150	30.0
3.30	165	29.4	175	31.5
5.00	280	30.9	243	27.2

PRODUCT PREVIEW

DROPOUT VOLTAGE

The TPS7A7200 maintains its output voltage regulation with a dropout voltage ($V_{IN} - V_{OUT}$) greater than 0.25 V under the test conditions specified in the Electrical Characteristics. In most power distribution tree (system) designs, the TPS7A7200 can be used with a 0.3-V difference in the common voltage rails (for example, from 3.3 V_{IN} to 3.0 V_{OUT} , from 1.8 V_{IN} to 1.5 V_{OUT} , or from 1.5 V_{IN} to 1.2 V_{IN}).

INPUT CAPACITOR REQUIREMENTS

As a result of its very fast transient response and low-dropout operation support, it is necessary to reduce the line impedance at the input pin of the TPS7A7200. The line impedance depends heavily on various factors, such as wire (PCB trace) resistance, wire inductance, and/or output impedance of the upstream voltage supply (power supply to the TPS7A7200). Therefore, a specific value for the input capacitance cannot be recommended until the previously listed factors are finalized.

In addition, simple usage of large input capacitance is known to form unwanted LC resonance in combination with input wire inductance. For example, a 5-nH inductor and a 10- μ F input capacitor form an LC filter that has a resonance at 712 kHz. This value of 712 kHz is well inside the bandwidth of the TPS7A7200 control loop.

The best guideline is to use a capacitor of up to 1 μ F with well-designed wire connections (PCB layout) to the upstream supply. In case it is difficult to optimize the input line, use a large tantalum capacitor in combination with a good-quality, low-ESR, 1- μ F ceramic capacitor.

OUTPUT CAPACITOR REQUIREMENTS

The TPS7A7200 is designed to be stable with standard ceramic capacitors with capacitance values greater than or equal to 4.7 μ F. The TPS7A7200 is evaluated using an X5R-type, 10- μ F ceramic capacitor. X5R- and X7R-type capacitors are highly recommended because they have minimal variation in value and ESR over temperature. Maximum ESR should be below 1.0 Ω .

As with any regulator, increasing the size of the output capacitor reduces overshoot and undershoot magnitude, but increases duration of the transient response.

UNDERVOLTAGE LOCK-OUT (UVLO)

The TPS7A7200 uses an undervoltage lock-out circuit to keep the output shut off until the internal circuitry is operating properly. The UVLO circuit has a deglitch feature that typically ignores undershoot of the input voltage upon the event of device start-up. Still, a poor input line impedance may cause a severe input voltage drop when the device powers on. As explained in the [INPUT CAPACITOR REQUIREMENTS](#) section, the input line impedance should be well-designed.

SOFT-START

The TPS7A7200 has a SS pin that provides a soft-start (slow start) function.

By leaving the SS pin open, the TPS7A7200 performs a soft-start by its default setting.

As shown in [Figure 1](#), by connecting a capacitor between the SS pin and the ground, the C_{SS} capacitor forms an RC pair together with the integrated 50-k Ω resistor. The RC pair operates as an RC-delay circuit for the soft-start together with the internal 700- μ s delay circuit.

The relationship between C_{SS} and the soft-start time is shown in [Figure 31](#) through [Figure 33](#).

CURRENT LIMIT

The TPS7A7200 internal current limit circuitry protects the regulator during fault conditions. During a current limit event, the output sources a fixed amount of current that is mostly independent of the output voltage. The current limit function is provided as a fail-safe mechanism and is not intended to be used regularly. Do not design any applications to use this current limit function as a part of expected normal operation. Extended periods of current limit operation degrade device reliability.

ENABLE AND SHUTDOWN THE DEVICE

The EN pin switches the enable and disable (shutdown) states of the TPS7A7200. A logic high input at the EN pin enables the device; a logic low input disables the device. When disabled, the device consumption current is reduced.

POWER GOOD

The TPS7A7200 has a power good function that works with the PG output pin. When the output voltage undershoots the threshold voltage $V_{IT(PG)}$ during normal operation, the PG open-drain output turns from a high-impedance state to a low-impedance state. When the output voltage exceeds the $V_{IT(PG)}$ threshold by an amount greater than the PG hysteresis, $V_{hys(PG)}$, the PG open-drain output turns from a low-impedance state to high-impedance state. By connecting a pull-up resistor (usually between OUT and PG), any downstream device can receive an active-high enable logic signal.

When setting the output voltage to less than 1.8 V and using a pull-up resistor between OUT and PG, depending on the downstream device specifications, the downstream device may not accept the PG output as a valid high-level logic voltage. In such cases, put a pull-up resistor between IN and PG, not between OUT and PG.

Figure 19 shows the open-drain output drive capability. The on-resistance of the open-drain transistor is calculated using Figure 19, and is approximately 200 Ω . Any pull-up resistor greater than 10 k Ω works fine for this purpose.

THERMAL INFORMATION

Thermal Protection

The thermal protection feature disables the output when the junction temperature rises to approximately +160°C, allowing the device to cool. When the junction temperature cools to approximately +140°C, the output circuitry is enabled. Depending on power dissipation, thermal resistance, and ambient temperature, the thermal protection circuit may cycle on and off. This thermal limit protects the device from damage as a result of overheating.

Any tendency to activate the thermal protection circuit indicates excessive power dissipation or an inadequate heatsink. For reliable operation, junction temperature should be limited to +125°C maximum. To estimate the margin of safety in a complete design (including heatsink), increase the ambient temperature until the thermal protection is triggered; use worst-case loads and signal conditions. For good reliability, thermal protection should trigger at least +35°C above the maximum expected ambient condition of your particular application. This configuration produces a worst-case junction temperature of +125°C at the highest expected ambient temperature and worst-case load.

The internal protection circuitry of the TPS7A7200 has been designed to protect against overload conditions. It was not intended to replace proper heatsinking. Continuously running the TPS7A7200 into thermal shutdown degrades device reliability.

Power Dissipation

Knowing the device power dissipation and proper sizing of the thermal plane that is connected to the tab or pad is critical to avoiding thermal shutdown and ensuring reliable operation.

Power dissipation of the device depends on input voltage and load conditions and can be calculated using Equation 1:

$$P_D = (V_{IN} - V_{OUT}) \times I_{OUT} \quad (1)$$

Power dissipation can be minimized and greater efficiency can be achieved by using the lowest possible input voltage necessary to achieve the required output voltage regulation.

On the QFN (RGW) package, the primary conduction path for heat is through the exposed pad to the printed circuit board (PCB). The pad can be connected to ground or be left floating; however, it should be attached to an appropriate amount of copper PCB area to ensure the device does not overheat. The maximum junction-to-ambient thermal resistance depends on the maximum ambient temperature, maximum device junction temperature, and power dissipation of the device and can be calculated using Equation 2:

$$R_{\theta JA} = \left(\frac{+125^{\circ}\text{C} - T_A}{P_D} \right) \quad (2)$$

Knowing the maximum $R_{\theta JA}$, the minimum amount of PCB copper area needed for appropriate heatsinking can be estimated using Figure 41.

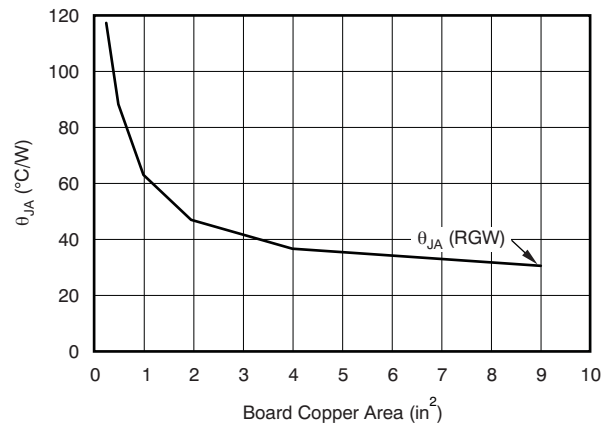

NOTE: θ_{JA} value at a board size of 9-in² (that is, 3-in × 3-in) is a JEDEC standard.

Figure 41. θ_{JA} vs Board Size

Figure 41 shows the variation of θ_{JA} as a function of ground plane copper area in the board. It is intended only as a guideline to demonstrate the effects of heat spreading in the ground plane and should not be used to estimate actual thermal performance in real application environments.

NOTE: When the device is mounted on an application PCB, it is strongly recommended to use Ψ_{JT} and Ψ_{JB} , as explained in the *Estimating Junction Temperature* section.

Estimating Junction Temperature

Using the thermal metrics Ψ_{JT} and Ψ_{JB} , as shown in the *Thermal Information* table, the junction temperature can be estimated with corresponding formulas (given in Equation 3). For backwards compatibility, an older $\theta_{JC, Top}$ parameter is listed as well.

$$\Psi_{JT}: T_J = T_T + \Psi_{JT} \cdot P_D$$

$$\Psi_{JB}: T_J = T_B + \Psi_{JB} \cdot P_D$$

Where:

P_D is the power dissipation shown by Equation 2.

T_T is the temperature at the center-top of the IC package.

T_B is the PCB temperature measured 1mm away from the IC package on the PCB surface (as Figure 43 shows). (3)

NOTE: Both T_T and T_B can be measured on actual application boards using a thermo-gun (an infrared thermometer).

For more information about measuring T_T and T_B , see Application Report SBVA025, *Using New Thermal Metrics*, available for download at www.ti.com.

By looking at [Figure 42](#), the new thermal metrics (Ψ_{JT} and Ψ_{JB}) have very little dependency on board size. That is, using Ψ_{JT} or Ψ_{JB} with [Equation 3](#) is a good way to estimate T_J by simply measuring T_T or T_B , regardless of the application board size.

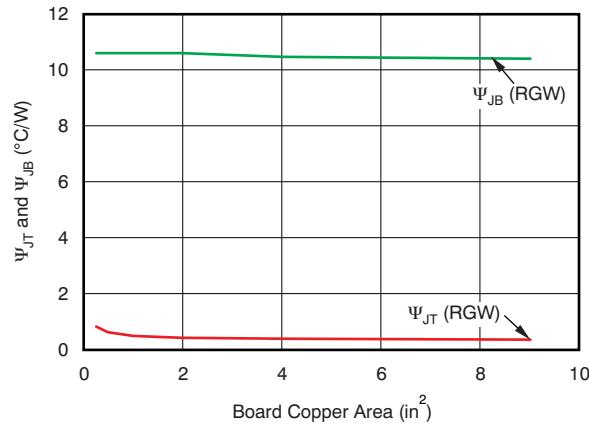
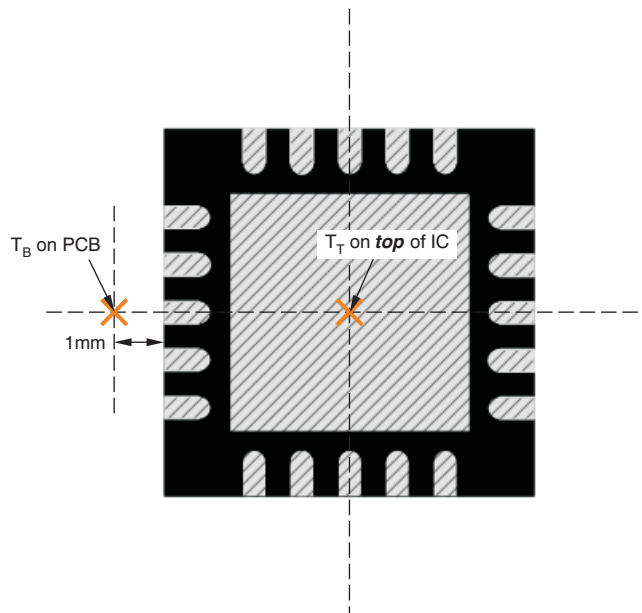

Figure 42. Ψ_{JT} and Ψ_{JB} vs Board Size

For a more detailed discussion of why TI does not recommend using $\theta_{JC(top)}$ to determine thermal characteristics, refer to Application Report [SBVA025](#), *Using New Thermal Metrics*, available for download at [www.ti.com](#). For further information, refer to Application Report [SPRA953](#), *IC Package Thermal Metrics*, also available on the TI website.

PRODUCT PREVIEW



(a) Example RGW (QFN) Package Measurement

Figure 43. Measuring Points for T_T and T_B

PACKAGING INFORMATION

Orderable Device	Status ⁽¹⁾	Package Type	Package Drawing	Pins	Package Qty	Eco Plan ⁽²⁾	Lead/ Ball Finish	MSL Peak Temp ⁽³⁾	Samples (Requires Login)
TPS7A7200RGWR	ACTIVE	VQFN	RGW	20	3000	Green (RoHS & no Sb/Br)	CU NIPDAUAG	Level-2-260C-1 YEAR	
TPS7A7200RGWT	ACTIVE	VQFN	RGW	20	250	Green (RoHS & no Sb/Br)	CU NIPDAUAG	Level-2-260C-1 YEAR	

⁽¹⁾ The marketing status values are defined as follows:

ACTIVE: Product device recommended for new designs.

LIFEBUY: TI has announced that the device will be discontinued, and a lifetime-buy period is in effect.

NRND: Not recommended for new designs. Device is in production to support existing customers, but TI does not recommend using this part in a new design.

PREVIEW: Device has been announced but is not in production. Samples may or may not be available.

OBsolete: TI has discontinued the production of the device.

⁽²⁾ Eco Plan - The planned eco-friendly classification: Pb-Free (RoHS), Pb-Free (RoHS Exempt), or Green (RoHS & no Sb/Br) - please check <http://www.ti.com/productcontent> for the latest availability information and additional product content details.

TBD: The Pb-Free/Green conversion plan has not been defined.

Pb-Free (RoHS): TI's terms "Lead-Free" or "Pb-Free" mean semiconductor products that are compatible with the current RoHS requirements for all 6 substances, including the requirement that lead not exceed 0.1% by weight in homogeneous materials. Where designed to be soldered at high temperatures, TI Pb-Free products are suitable for use in specified lead-free processes.

Pb-Free (RoHS Exempt): This component has a RoHS exemption for either 1) lead-based flip-chip solder bumps used between the die and package, or 2) lead-based die adhesive used between the die and leadframe. The component is otherwise considered Pb-Free (RoHS compatible) as defined above.

Green (RoHS & no Sb/Br): TI defines "Green" to mean Pb-Free (RoHS compatible), and free of Bromine (Br) and Antimony (Sb) based flame retardants (Br or Sb do not exceed 0.1% by weight in homogeneous material)

⁽³⁾ MSL, Peak Temp. -- The Moisture Sensitivity Level rating according to the JEDEC industry standard classifications, and peak solder temperature.

Important Information and Disclaimer: The information provided on this page represents TI's knowledge and belief as of the date that it is provided. TI bases its knowledge and belief on information provided by third parties, and makes no representation or warranty as to the accuracy of such information. Efforts are underway to better integrate information from third parties. TI has taken and continues to take reasonable steps to provide representative and accurate information but may not have conducted destructive testing or chemical analysis on incoming materials and chemicals. TI and TI suppliers consider certain information to be proprietary, and thus CAS numbers and other limited information may not be available for release.

In no event shall TI's liability arising out of such information exceed the total purchase price of the TI part(s) at issue in this document sold by TI to Customer on an annual basis.

RGW (S-PVQFN-N20)

PLASTIC QUAD FLATPACK NO-LEAD

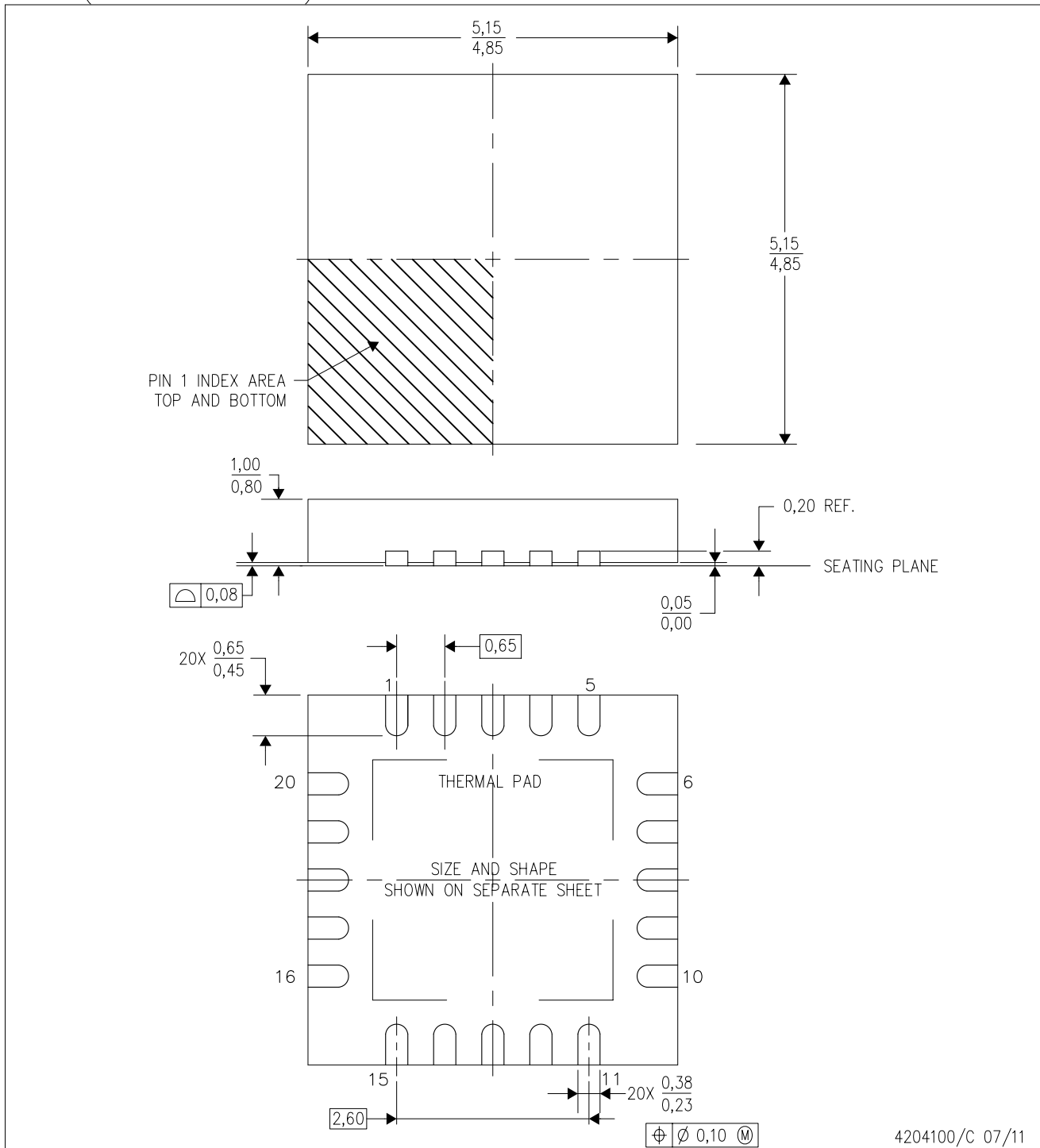

- NOTES:
- A. All linear dimensions are in millimeters. Dimensioning and tolerancing per ASME Y14.5-1994.
 - B. This drawing is subject to change without notice.
 - C. Quad Flat pack, No-leads (QFN) package configuration
 - D. The package thermal pad must be soldered to the board for thermal and mechanical performance.
 - E. See the additional figure in the Product Data Sheet for details regarding the exposed thermal pad features and dimensions.
 - F. Falls within JEDEC MO-220.

THERMAL PAD MECHANICAL DATA

RGW (S-PVQFN-N20)

PLASTIC QUAD FLATPACK NO-LEAD

THERMAL INFORMATION

This package incorporates an exposed thermal pad that is designed to be attached directly to an external heatsink. The thermal pad must be soldered directly to the printed circuit board (PCB). After soldering, the PCB can be used as a heatsink. In addition, through the use of thermal vias, the thermal pad can be attached directly to the appropriate copper plane shown in the electrical schematic for the device, or alternatively, can be attached to a special heatsink structure designed into the PCB. This design optimizes the heat transfer from the integrated circuit (IC).

For information on the Quad Flatpack No-Lead (QFN) package and its advantages, refer to Application Report, QFN/SON PCB Attachment, Texas Instruments Literature No. SLUA271. This document is available at www.ti.com.

The exposed thermal pad dimensions for this package are shown in the following illustration.

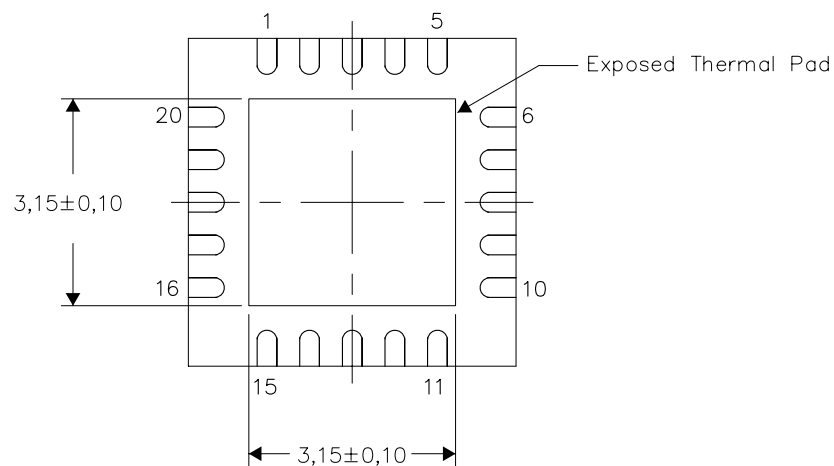

Bottom View

Exposed Thermal Pad Dimensions

4206352-2/J 07/11

NOTE: All linear dimensions are in millimeters

IMPORTANT NOTICE

Texas Instruments Incorporated and its subsidiaries (TI) reserve the right to make corrections, modifications, enhancements, improvements, and other changes to its products and services at any time and to discontinue any product or service without notice. Customers should obtain the latest relevant information before placing orders and should verify that such information is current and complete. All products are sold subject to TI's terms and conditions of sale supplied at the time of order acknowledgment.

TI warrants performance of its hardware products to the specifications applicable at the time of sale in accordance with TI's standard warranty. Testing and other quality control techniques are used to the extent TI deems necessary to support this warranty. Except where mandated by government requirements, testing of all parameters of each product is not necessarily performed.

TI assumes no liability for applications assistance or customer product design. Customers are responsible for their products and applications using TI components. To minimize the risks associated with customer products and applications, customers should provide adequate design and operating safeguards.

TI does not warrant or represent that any license, either express or implied, is granted under any TI patent right, copyright, mask work right, or other TI intellectual property right relating to any combination, machine, or process in which TI products or services are used. Information published by TI regarding third-party products or services does not constitute a license from TI to use such products or services or a warranty or endorsement thereof. Use of such information may require a license from a third party under the patents or other intellectual property of the third party, or a license from TI under the patents or other intellectual property of TI.

Reproduction of TI information in TI data books or data sheets is permissible only if reproduction is without alteration and is accompanied by all associated warranties, conditions, limitations, and notices. Reproduction of this information with alteration is an unfair and deceptive business practice. TI is not responsible or liable for such altered documentation. Information of third parties may be subject to additional restrictions.

Resale of TI products or services with statements different from or beyond the parameters stated by TI for that product or service voids all express and any implied warranties for the associated TI product or service and is an unfair and deceptive business practice. TI is not responsible or liable for any such statements.

TI products are not authorized for use in safety-critical applications (such as life support) where a failure of the TI product would reasonably be expected to cause severe personal injury or death, unless officers of the parties have executed an agreement specifically governing such use. Buyers represent that they have all necessary expertise in the safety and regulatory ramifications of their applications, and acknowledge and agree that they are solely responsible for all legal, regulatory and safety-related requirements concerning their products and any use of TI products in such safety-critical applications, notwithstanding any applications-related information or support that may be provided by TI. Further, Buyers must fully indemnify TI and its representatives against any damages arising out of the use of TI products in such safety-critical applications.

TI products are neither designed nor intended for use in military/aerospace applications or environments unless the TI products are specifically designated by TI as military-grade or "enhanced plastic." Only products designated by TI as military-grade meet military specifications. Buyers acknowledge and agree that any such use of TI products which TI has not designated as military-grade is solely at the Buyer's risk, and that they are solely responsible for compliance with all legal and regulatory requirements in connection with such use.

TI products are neither designed nor intended for use in automotive applications or environments unless the specific TI products are designated by TI as compliant with ISO/TS 16949 requirements. Buyers acknowledge and agree that, if they use any non-designated products in automotive applications, TI will not be responsible for any failure to meet such requirements.

Following are URLs where you can obtain information on other Texas Instruments products and application solutions:

Products

Audio	www.ti.com/audio
Amplifiers	amplifier.ti.com
Data Converters	dataconverter.ti.com
DLP® Products	www.dlp.com
DSP	dsp.ti.com
Clocks and Timers	www.ti.com/clocks
Interface	interface.ti.com
Logic	logic.ti.com
Power Mgmt	power.ti.com
Microcontrollers	microcontroller.ti.com
RFID	www.ti-rfid.com
OMAP Mobile Processors	www.ti.com/omap
Wireless Connectivity	www.ti.com/wirelessconnectivity

Applications

Automotive and Transportation	www.ti.com/automotive
Communications and Telecom	www.ti.com/communications
Computers and Peripherals	www.ti.com/computers
Consumer Electronics	www.ti.com/consumer-apps
Energy and Lighting	www.ti.com/energy
Industrial	www.ti.com/industrial
Medical	www.ti.com/medical
Security	www.ti.com/security
Space, Avionics and Defense	www.ti.com/space-avionics-defense
Video and Imaging	www.ti.com/video

TI E2E Community Home Page

e2e.ti.com

Mailing Address: Texas Instruments, Post Office Box 655303, Dallas, Texas 75265
Copyright © 2012, Texas Instruments Incorporated